

ELECTRONIC CONTROL
ACTUATOR

“ Nucom Series ”

LINEAR TYPE

Nucom – L40S

OPERATION MANUAL

Koei Industry Co., Ltd.

FOR YOUR SAFETY

In order for better and safety use of the product for a long period, please observe this “WARNING and CAUTION “ carefully.

Here are the specification and operation manual for the product to prevent suffering injury or loss by accidents.

The contents are divided into “WARNING” and “CAUTION” for different degree of risks.

Please strictly observe them, as both of them are very important for your safety.



WARNING : Improper handling of the product disregarding the notes under this mark may cause injury or death to a man.



CAUTION : Improper handling of the product disregarding the notes under this mark may cause injury or material loss.



WARNING

- * This product is not of explosion-proof.
Do not use it in the environment with flammable gas (gasoline etc.) or corrosive gas.
- * Do not dismantle the actuator from the valve during power operation.
- * Do not make wiring work when power is being supplied.



CAUTION

- * Do not drop the product or give a shock to the product, for it may cause defects to the product.
- * Do not get on the actuator, or it may cause defects or an accident.
- * Do not make wiring work in the rain or in splashing water.



CONTENTS



1. GENERAL
2. CONFIGURATION AND NAMES OF PARTS
3. FUNCTIONAL SPECIFICATION
4. OPERATION PRINCIPLE
5. INSTALLATION
 - 5.1 Installation place
 - 5.2 Ambient temperature, fluid temperature
6. ASSEMBLY WITH A VALVE
7. WIRING
 - 7-1 Wiring with power / input signal
 - 7-2 Wiring work
8. RATED POWER / INPUT SIGNAL AND WIRING DIAGRAM
 - 8-1 Rated power
 - 8-2 Input signal
 - 8-3 Recommendable fuse or breaker
 - 8-4 Wiring diagram
9. CONTROL PACK
 - 9-1 Names of parts
 - 9-2 Mode selection
 - 9-3 Sensitivity volume and ZERO / SPAN adjustment
10. OPERATION
 - 10-1 Manual operation
 - 10-2 Power operation
11. ADJUSTMENT
 - 11-1 Names of parts
 - 11-2 Adjustment
12. MAINTENANCE / INSPECTION
13. TROUBLE SHOOTING

1. GENERAL

The system is a linear type Electronic Actuator to continuously position valve opening with direct signals (4 ~ 20mA) from a controller or computer.

The system is robust, maintenance free and far more precise (Resolution 1/250) than traditional pneumatic actuators, and will help save process equipment and running costs.

∞ FEATURES

- * Compact and light
- * High resolution (More than 1/250)
- * Direct / reverse action selectable by mode selection switch
- * Open/Close/Stop mode during power interruption selectable by mode selection switch
- * Resin-molded servo control pack is designed to water and vibration proof
- * Helps simplify process flow
- * Saves process equipment and running costs to one over decades compared with pneumatic system.
- * Torque limiter and impedance protection motor fitted to prevent motor-burnout

2. CONFIGURATION AND NAMES OF PARTS

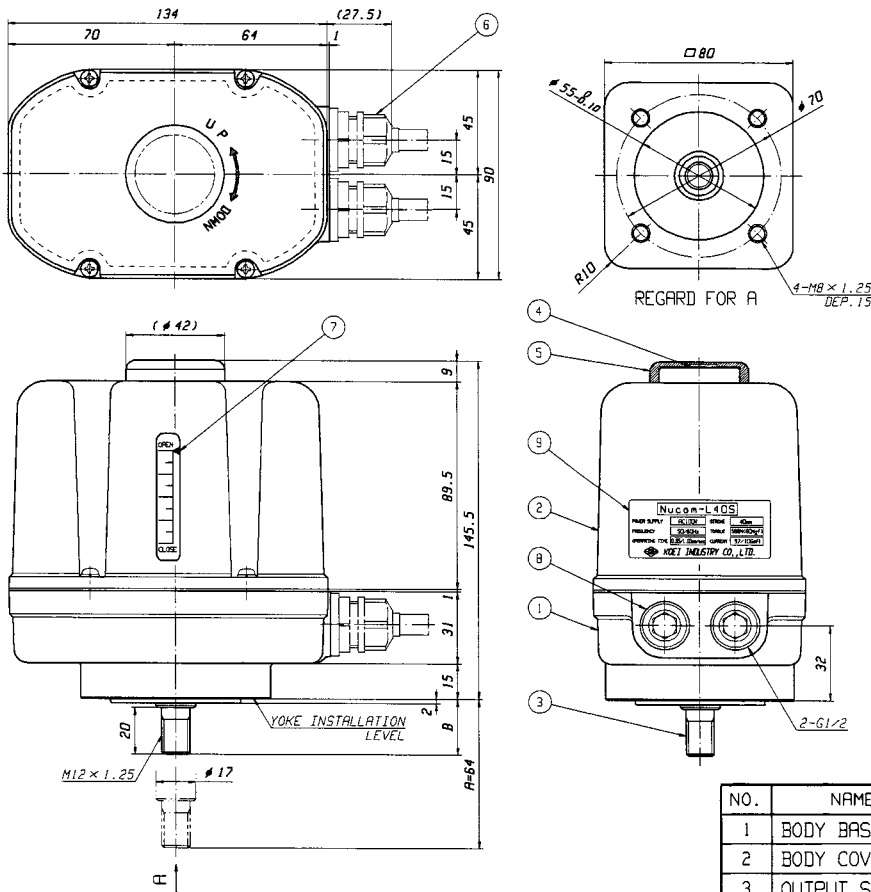

NO.	NAME OF PART	Q`TY	M T L	REMARKS
1	BODY BASE	1	ADC12	
2	BODY COVER	1	ADC12	
3	OUTPUT SHAFT	1	SUS303	
4	MANUAL HANDLE SHAFT	1	SUS303	
5	RUBBER CAP	1	NBR	
6	LEAD IN HOLE	2	DA-W16-11	OPTION
7	APERTOMETER	1	CLEAR RESIN	
8	BLIND PURAG	2	BLACK RESIN	
9	SPECIFICATION LABEL	1	TETORON	

3. FUNCTIONAL SPECIFICATION

ITEM \ MODEL	Nucom-L40S
RATED VOLTAGE	AC100/110/115/120V ± 10% (50/60 Hz) AC200/220/230/240V ± 10% (50/60 Hz)
INPUT SIGNAL	4~20mA DC(1~5V DC) (Standard spec) 4~12/ 12~20 mA DC (Option spec)
SHAFT OUTPUT	588N(60kgf)
OPERATION SPEED	0.86mm/sec(50Hz) 1.03mm/sec(60Hz)
SHAFT STROKE	0~40mm
RESOLUTION	Over 1/250
DEAD ZONE	0.5% F.S.
LINEARITY	0.5% F.S.
ACTION MODE	Direct(DA), Reverse(RA) Selectable
MODE DURING SIGNAL "OFF"	Close/Open/Stop Selectable
PROTECTION SYSTEM	* Top position limit switch fitted(Standard spec.) * Bottom torque limiter fitted(Standard spec.)
AMBIENT TEMPERATURE	-25~55°C
RATED CURRENT	97mA(AC100V) 106mA(AC110V) 67mA(AC200V) 74mA(AC220V)
MOTOR	Synchronous motor 3W (Impedance protection type)
INSULATION GRADE	E Class
DUTY RATING	Continuous
POSITION DETECTION	Potentiometer
OUTPUT SIGNAL	1~5V DC (Output impedance 1kΩ)
INSULATION RESISTANCE	500V DC/100MΩ between terminal and body
WITHSTAND VOLTAGE	1000V AC/1 minute between motor coil and body
TERMINAL	6-pin terminal block (Control pack)
MANUAL OVERRIDE	Allen key (Opposite 4mm)
CONDUIT	G1/2 × 2
WATER PROTECTION	To NEMA-4X (IP-67)
EXPLOSION PROOF	Non-explosion proof
MOUNTING ANGLE	Angle free
BODY MATERIAL	Die cast aluminum (ADC12)
COATING	Grey (Munsell scale N-6)
WEIGHT	Approx. 2.0kg

4. OPERATION PRINCIPLE

Control pack (Electronic module) makes relational operation between input signals (4~20mA) and position signals detected by potentiometer, and drives motor in direction to balance both the signals. Motor stops at the position where both the signals are balanced.

Motor revolution (Direct and reverse) is transmitted in the order of

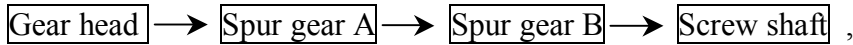

then converted into linear movement to stroke main shaft up and down.

Potentiometer always detects the shaft movement and feedbacks it to control pack.

The sequence of the above movement allows the system to continuously perform proportional operation against input signals.

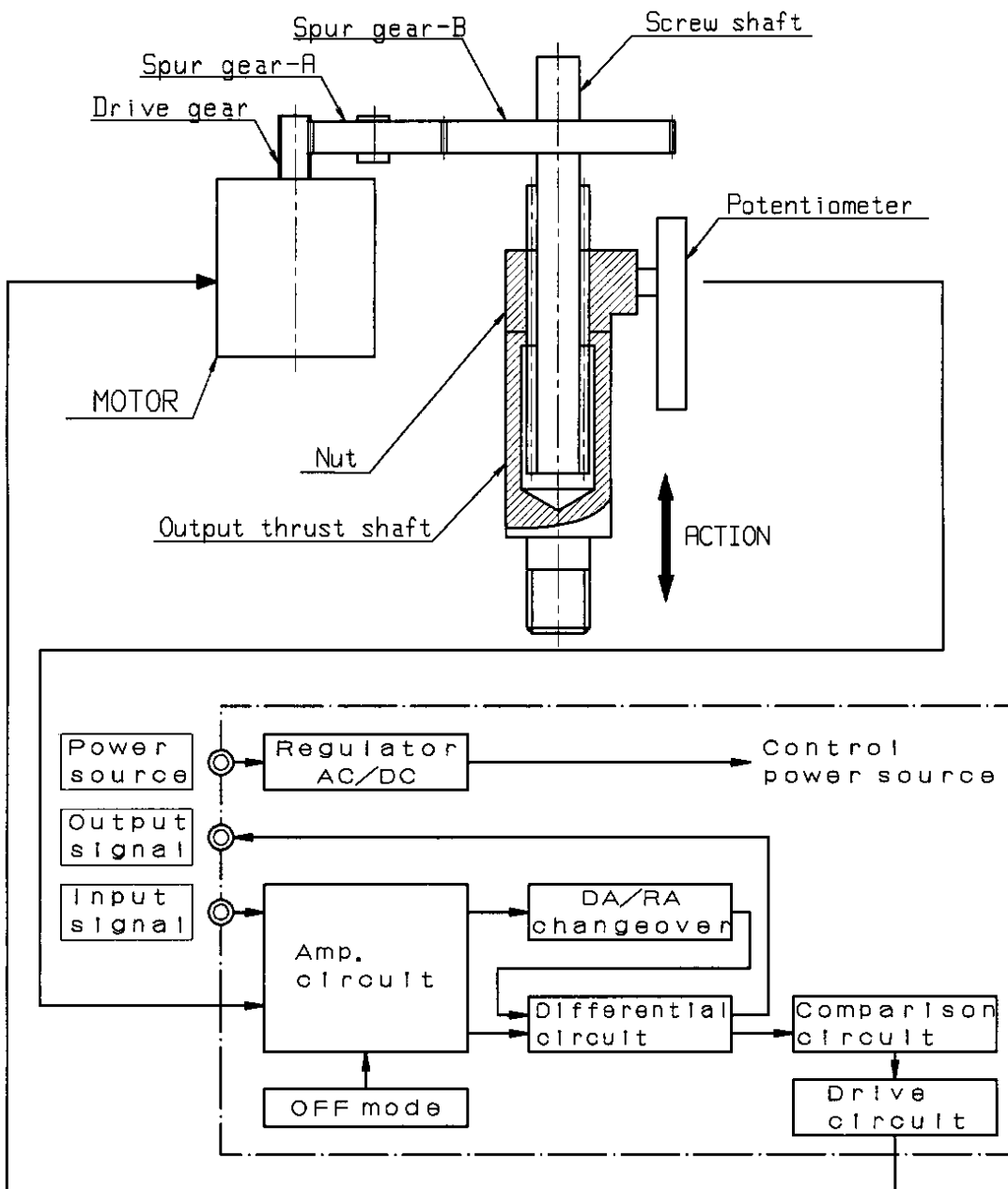

**CAUTION ON ENVIRONMENTAL INSTALLATION CONDITIONS****5. INSTALLATION****5-1. Installation place****⊗ Caution on indoor installation**

- * The actuators are not of explosion-proof type. Avoid to install in a hazardous place.
- * In case of installation in a place where water or materials are always splashing, it is necessary to cover whole the unit.
- * It is recommendable to reserve a space for manual maintenance work.
(depends on installation conditions)

⊗ Caution on outdoor installation

- * To avoid rainwater or direct sunlight, cover or shade whole the unit.
(This concerns temperature rise in the unit, and anti-climate property of seals used.)
- * It is recommendable to reserve a space for manual maintenance work.
(depends on installation conditions)

**Actuator surface materials and treatment**

PART \ MODEL	Nucom-L40S
BODY BASE	Die cast Aluminum Oxidation treatment Electrostatic coating
BODY COVER	Die cast Aluminum Oxidation treatment Electrostatic coating
OUTPUT SHAFT	SUS 303
DUST COVER ON MANUAL OVERRIDE	NBR
OIL SEAL	NBR

5-2 Ambient temperature / fluid temperature**⊗ Ambient temperature**

- * Environmental temperature range for use : $-25^{\circ}\text{C}\sim 55^{\circ}\text{C}$.
- * For use in minus temperature, space-heater is available at option.
- * For use in temperature beyond the specified range, refer to our Sales Dept.

⊗ Fluid temperature

It is occasional that if the actuators are applied to high temperature fluid lines, the unit may be overheated by transmission of the line heat. In such a case, we suggest using radiation type yoke and coupling for high temperature application.

⚠ CAUTION ON ASSEMBLY WITH A VALVE

6. ASSEMBLY WITH A VALVE

⊗ Names of parts

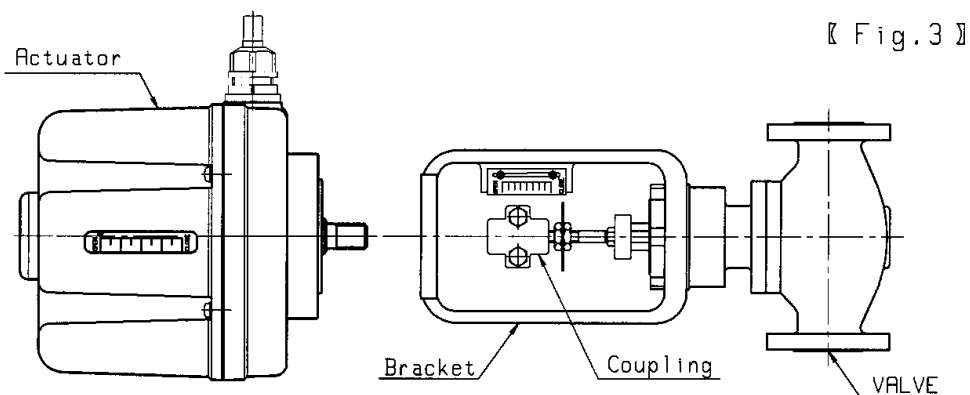

As shown in Fig.3, the actuator and a valve are individually structured for easy disengagement when trouble is occurred.

⊗ Assembly procedure

1. Be sure that power is off before making manual operation.
2. Drive the valve manually and confirm that it is normal.
Then set it at full close position.
3. Fit a bracket to the actuator.
4. After the actuator is set at full close, engage output shaft and the valve stem with coupling.
5. Manually drive the actuator, and make sure that it moves smoothly without eccentricity.

⚠ CAUTION ON WIRING WORK

7. WIRING

7-1 Wiring of power and signal cables

Remove the side plate cover (or body cover), and find 6-P terminal block inside.

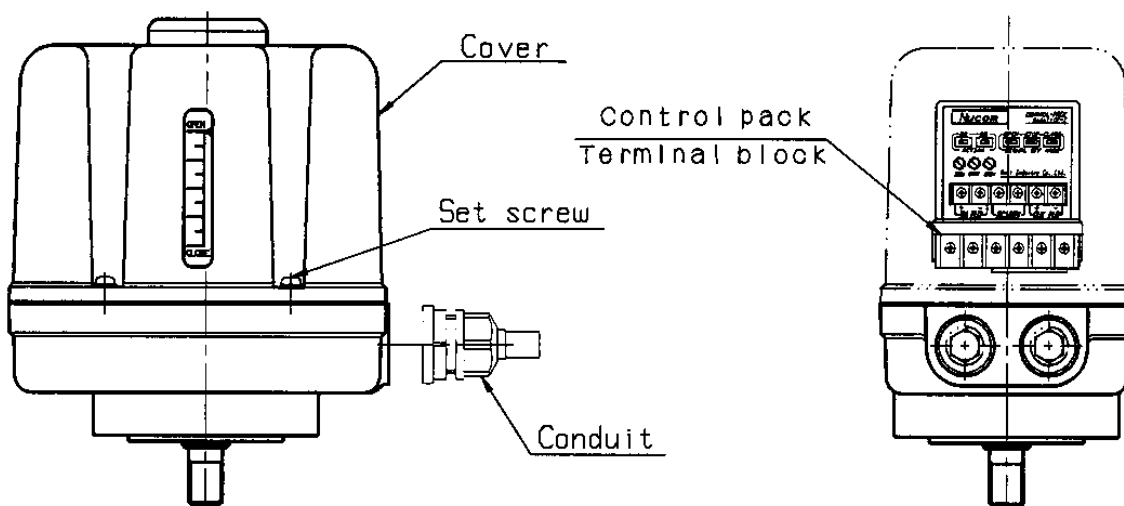

⌘ Caution on wiring

A qualified person based on electric equipment technical standard should make wiring work. Refrain from wiring work under rainy or high humid conditions.

Make proper wiring to the wiring diagram.

For all connections use fork crimped-on terminals.

For the standard resin conduit, use a cable of outer diameter $\phi 9\sim\phi 11$ mm. (Refer to Fig.5)

For customer conduit, select a proper size cable to match it to avoid water ingress through the gap. Secure the cover and conduit tightly after power/signal wiring is over to avoid water ingress.

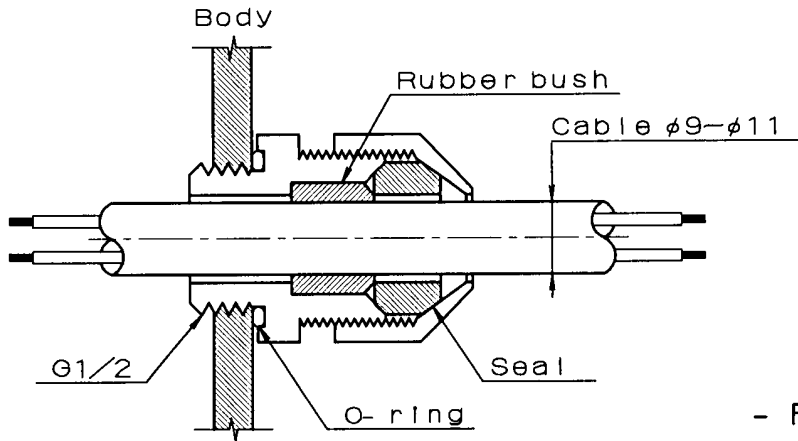

- FIG. 5 -

7-2 Wiring work

Use sufficiently shield tubes or conduit to prevent water ingress.

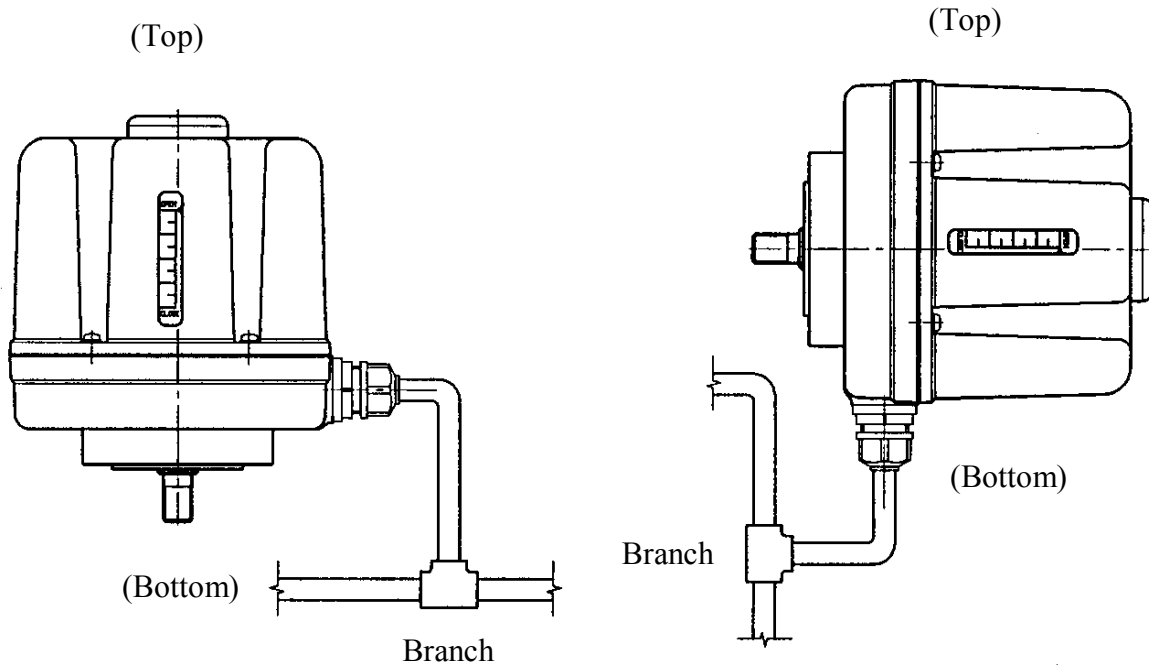

CAUTION ON USE

8. RATED POWER / INPUT SIGNAL AND WIRING DIAGRAM

8-1 Rated power

AC 100/110/115/120V ±10% (50/60Hz)
AC 200/220/230/240V ±10% (50/60Hz)

For different supply from the above, refer to our Sales Dept.

8-2 Input signal

4~20mA DC (1~5V DC)	Standard
4~12mA DC	Option
12~20mA DC	Option

Note: Wiring should be made properly to reject noise disturbance etc.

8-3 Recommendable fuse or breaker

Install a protection fuse or breaker on supply source according to the following table

Model	Capacity of fuse / breaker	Motor capacity
Nucom-L40S	0.5~1A	3W

8.4 Wiring diagram

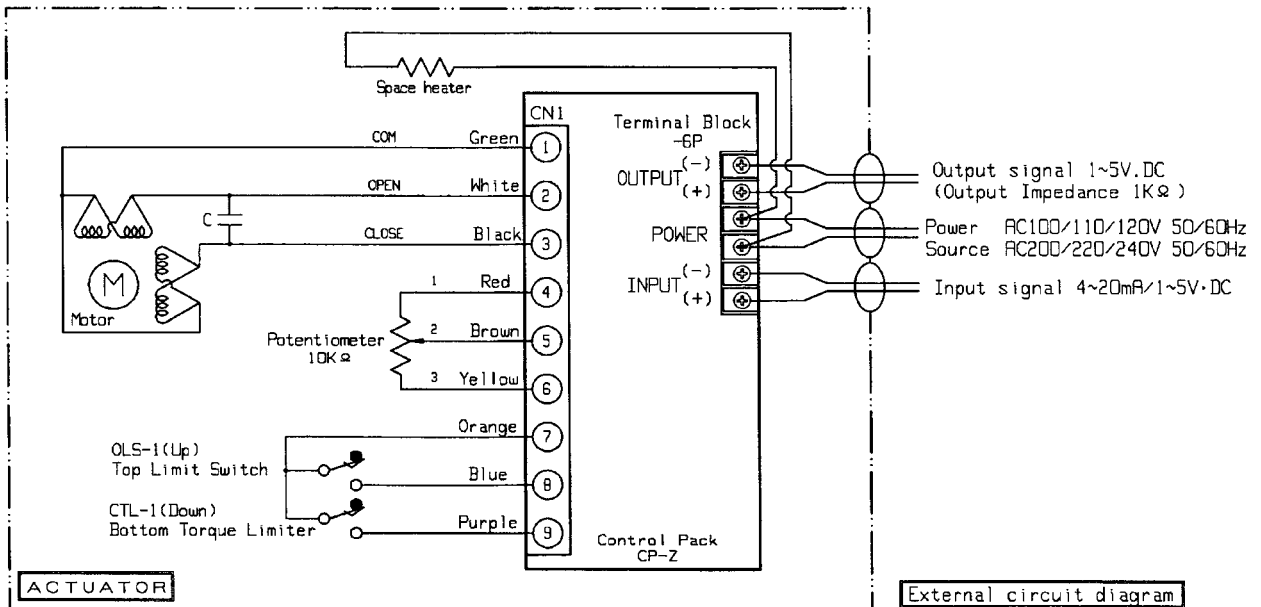

CAUTION ON USE

9. CONTROL PACK

9-1 Names of parts

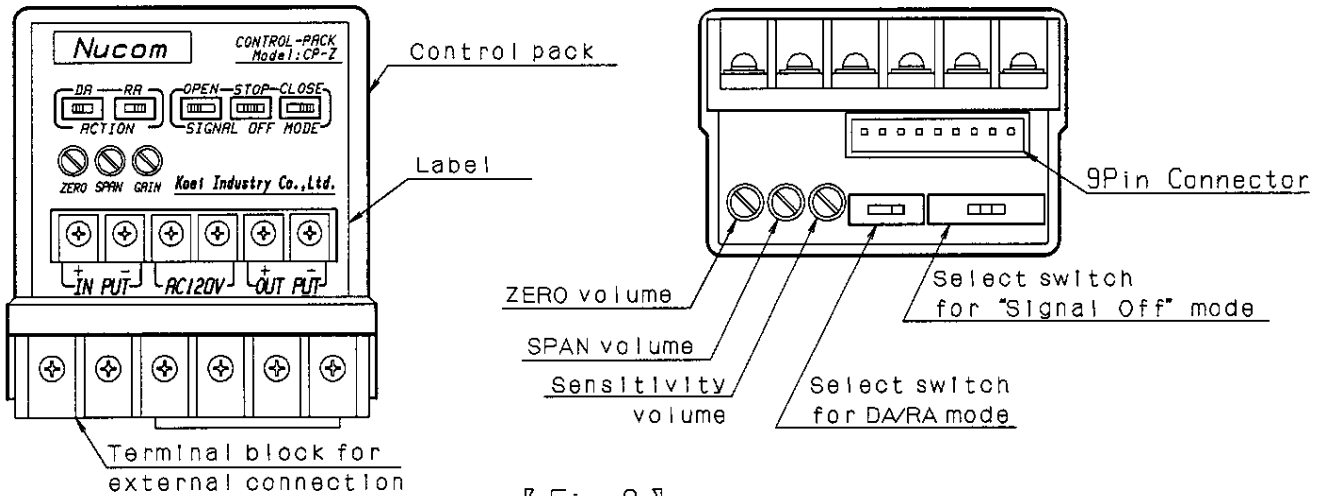

【 Fig.8 】

9-2 Mode selection

⊗ Input signal and operation direction

Direct or reverse action is selectable by Select switch.

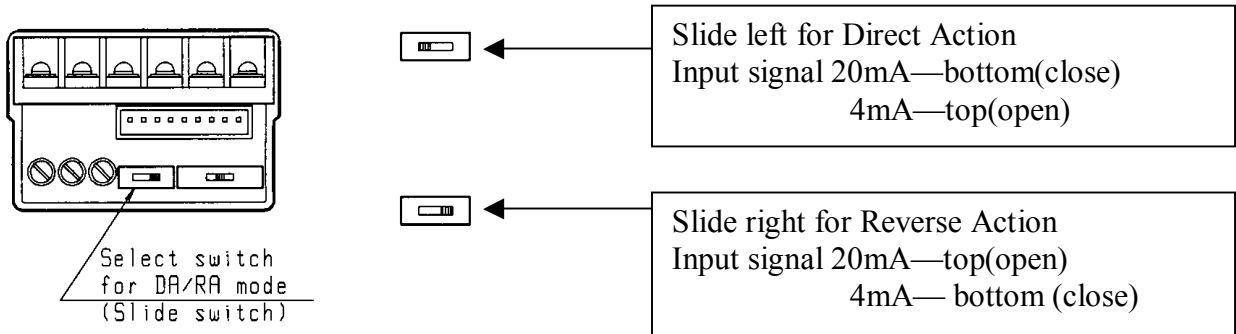

【 Fig.9 】

⊗ Action during signal interruption

When signal circuits are open or a signal is lowered below 2mA during operation, the system recognizes as “signal interrupted”, and stops movement at the preset position by Select switch.

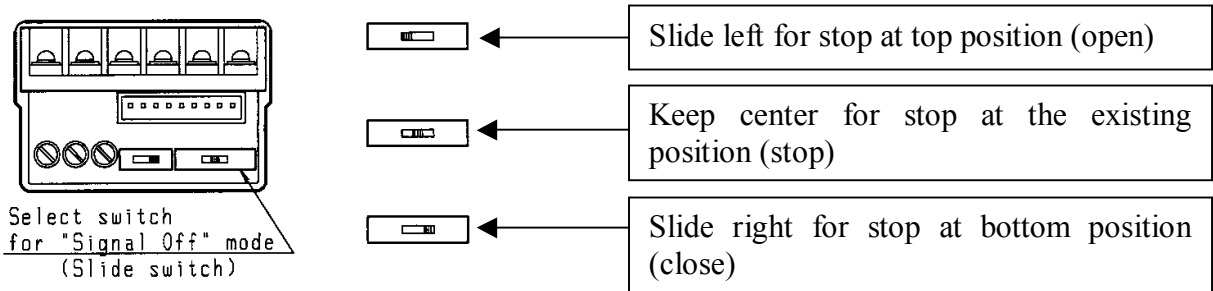

【 Fig.10 】

Note : Before setting a direction or action mode, be sure that power is off.

* Direct / reverse direction and action mode during signal interruption (signal “off”) may be set in the following 6 combinations.

DA				
	OPEN		STOP	CLOSE
RA				

【 Fig.11 】

* Unless expressly instructed, the unit is preset before shipment in combination of :

Action mode	RA
Signal “OFF” mode	Stop

Note : 4~20mA signals from a computer or controller should be accurately adjusted.
The unit recognizes any signals below 2mA as “signal interrupted” and will automatically operate accordingly.

9-3 Sensitivity volume and ZERO / SPAN adjustment

* Resolution is preset at 1/250 (0.4%) before shipment.

Noise disturbance on signals will unnecessarily and frequently drive the motor and will heavily shorten its life. In such a case, user may mitigate the influence of such disturbance by lowering sensitivity within an allowable range.

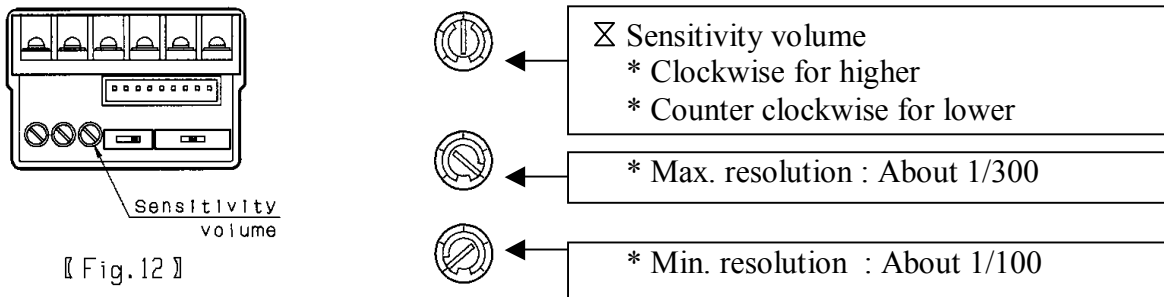

【 Fig.12 】

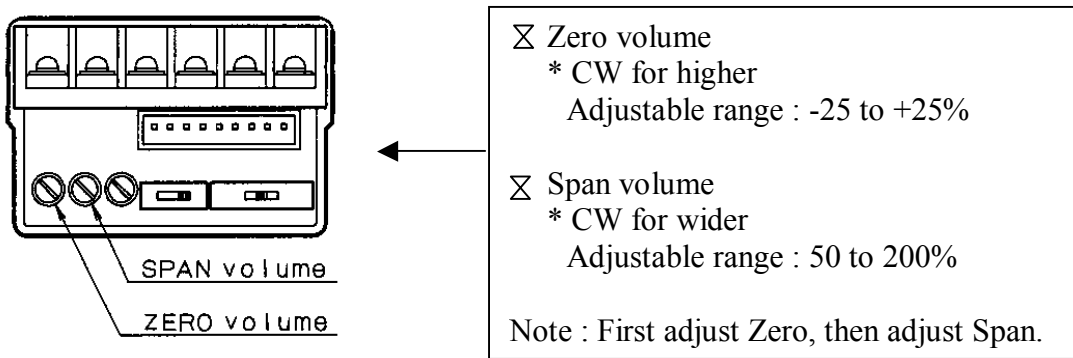

【 Fig.13 】

Note : ZERO / SPAN volume is pre-adjusted appropriately before shipment.
Do not re-adjust it unless it is expressly necessary.
For adjustment, use a trimmer driver within the torque range of 300g/cm.
Avoid to apply excessively large force, for it may cause troubles to the unit.



Confirm that power is OFF before making manual operation

10. OPERATION

10-1 Manual operation

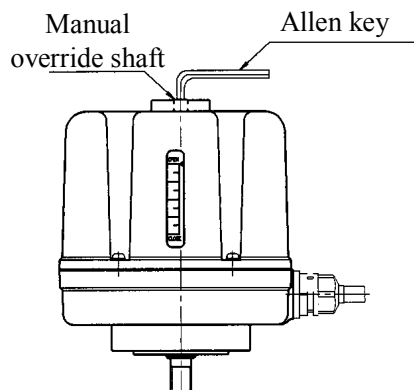

【 Fig. 14 】

1. Remove dust cover on the body and find a hexagon hole in the underneath.
 2. Insert allen key into the hole to turn the shaft CW for downward, CCW for upward.
- Note : Do not apply excessively large force beyond the operation range, for it may cause troubles to the unit.

Allen key hole	Opposite 4mm
Stroke	2mm /turn



CAUTION

When making manual operation,
be sure that power is off.
If power is on while manual operation,
the allen key will suddenly return!

10-2 Power operation

1. Before making power operation, confirm by manual operation that valve position is exactly matching with actuator at top / bottom limit positions.
Note : Confirm that the shaft moves smoothly without eccentricity etc.
2. Check that the wiring is properly made also confirm with external signals that valve is normally positioned at top and bottom limits.
3. Start operation after the above confirmation is over.

11. ADJUSTMENT

11-1 Names of parts

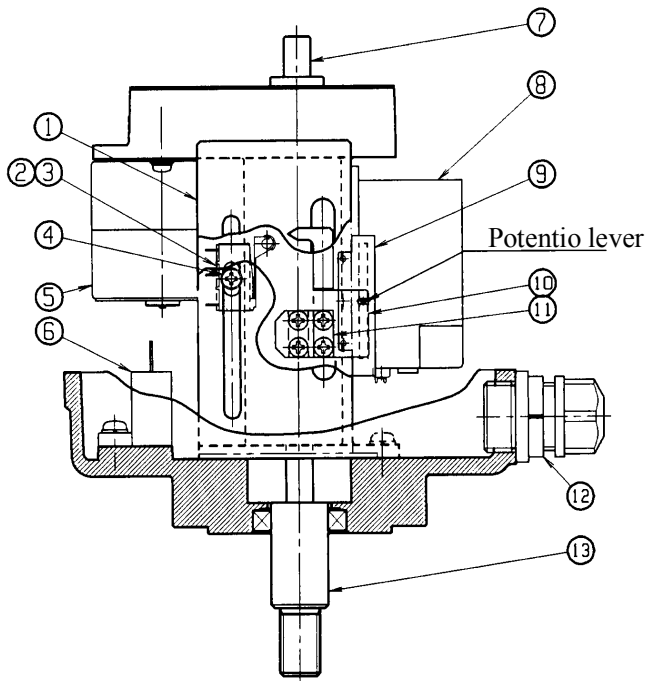

No.	Name of part	Remarks
1	Potentiometer fixing plate	SUS304
2	Top limit switch	
3	Roller for switch	ZnDC
4	Switch fixing screw	
5	Motor	
6	Condenser	
7	Manual handle shaft	
8	Control pack	
9	Potentiometer	
10	Position pointer	
11	Limit dog	ZnDC
12	Cable conduit	G1/2
13	Output shaft	SUS303

11-2 Adjustment

Verify every part in the above table, and make adjustment with care.

1. It is not necessary to make mechanical adjustment with potentiometer (No.9).

When necessary, adjust the length of output shaft by ZERO-SPAN volume located on the control pack (No.8).

In such a case, first set ZERO point (bottom limit), then SPAN.

RA: Adjust ZERO as 4mA → adjust SPAN as 20mA
 DA: Adjust ZERO as 20mA → adjust SPAN as 4mA

Potentiometer checking procedure

Potentiometer does not require mechanical adjustment, as it is linear type.

Confirm that potentio lever is inserted properly in the hole of pointer (No.10) of position indicator fixed with the limit dog, also that it slides smoothly along with output shaft.

2. For setting up limit (No.2), loosen and slowly slide roller (No.3), then fix it at a desired position.

Normally, the setting is made before shipment at a position upper by a half turn of the manual handle than input signal 20mA. (Shaft lead is 2mm).

Check that the top limit works at about 1mm upper position.

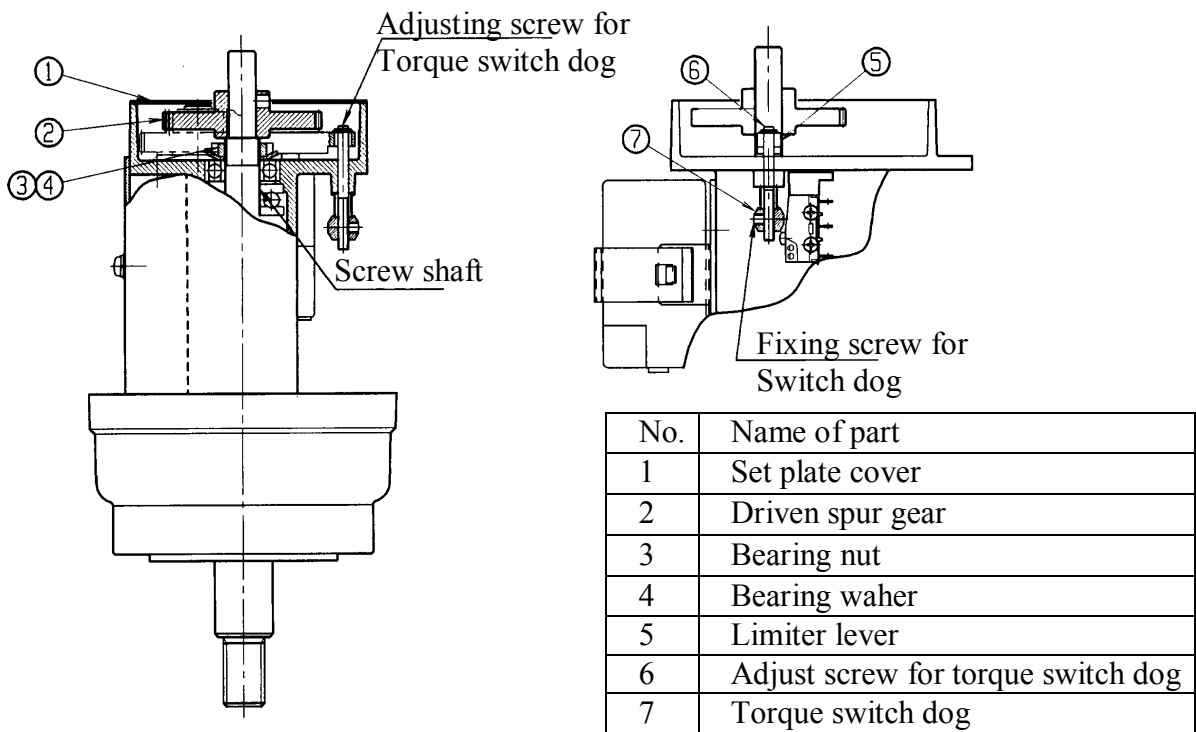

3. Torque limiter setting

Note when setting torque limiter

For setting torque limiter, use proper adjustment devices that can accurately detect a thrust. Make setting with care, or inaccurate setting may cause malfunctions.

- Loosen the screw for torque switch dog (No.7) allowing the dog to slide up and down by adjust screw (No.6, minus driver).
- Turn the adjust screw slowly. CW for increasing torque limiter setting rate, CCW for decreasing it.

Upon setting is made, along with downward load (valve setting torque), the switch dog (torque limiting mechanism) will go down and turn the switch letting the limiter work. (the motor will stop)

- After setting is over, secure the fixing screw. (Reverse the dog so as that the thread part will not touch the switch). Repeat testing the function a few times.

Note: If a setting rate is too small, the limiter may occasionally function even at a normal opening. If it is too large, the dog may not reach the switching point and the torque switch may not work. Make sure of the function if it is normal.

Caution for manual drive

Do not drive the unit manually any lower after the torque limiter has worked, or it may cause delicate effect on the limiter setting rate.

12. MAINTENANCE / INSPECTION

☒ Lubrication

As the major parts of the products are lubricated with long life anti-corrosive grease before shipment, re-lubrication is in principle not required.

☒ Inspection

When re-starting operation after a long period of rest, make the following confirmation.

1. Cut power off, confirm by manual operation that valve moves smoothly without eccentricity.
2. Open body cover and check if there is no condensation inside the unit, also no problem on wiring.

Note : After checking, firmly screw up the cover to prevent water ingress.

13. TROUBLE SHOOTING

TROUBLE AND PROBABLE CAUSE	SOLUTION
* MOTOR DOES NOT START UP	
Power is off	Supply power
Signal is off or below 2mA	Check signal
Circuits or terminal are open	Renew cables or re-connect terminal
Supply voltage is improper or too low	Check terminal voltage with a tester
Limit switch is faulty	Renew limit switch
Motor is defective or lead wire is broken	Renew actuator
Over capacity for motor advancer	Replace advancer (condenser)
Load is insufficient for torque limiter function (Check if lamp lights)	Change the setting rate for torque limiter
Wire connector is open	Insert connector (CN-1, 9-pin, white color) properly
* INPUT SIGNAL AND OPENING POSITION ARE NOT MATCHING EACH OTHER	
ZERO / SPAN adjustment is improper	Re-adjust ZERO / SPAN volumes
* MOTOR IS CONSTRAINED AT UPPER LIMIT	
Upper position limit switch is set out of range	Re-adjust the switch
Limit switch is faulty	Renew limit switch
* MOTOR IS CONSTRAINED AT LOWER LIMIT	
Setting rate for bottom torque limiter is too large	Change the setting rate for torque limiter
Limit switch is faulty	Change limit switch

* For other situation of troubles than the above, please refer to our Sales Dept.

* For any special version, contact our Sales Dept